

• SPECIFICATION •

• 1633HT - ARMSTRONG MINI FILTRATION TAP

- Handcrafted in the UK
- 1/4 turn ceramic disc flow control
- Vernier insert for accurate handle alignment
- Stainless steel filter housing
- Swiss made Katadyn filter
- Flow regulated filtration for optimum performance
- Filters down to 0.2 microns
- Activated carbon core Reduces Chlorine, odour and bad taste
- Heavy metal removal
- Filter replacement every 6 months recommended

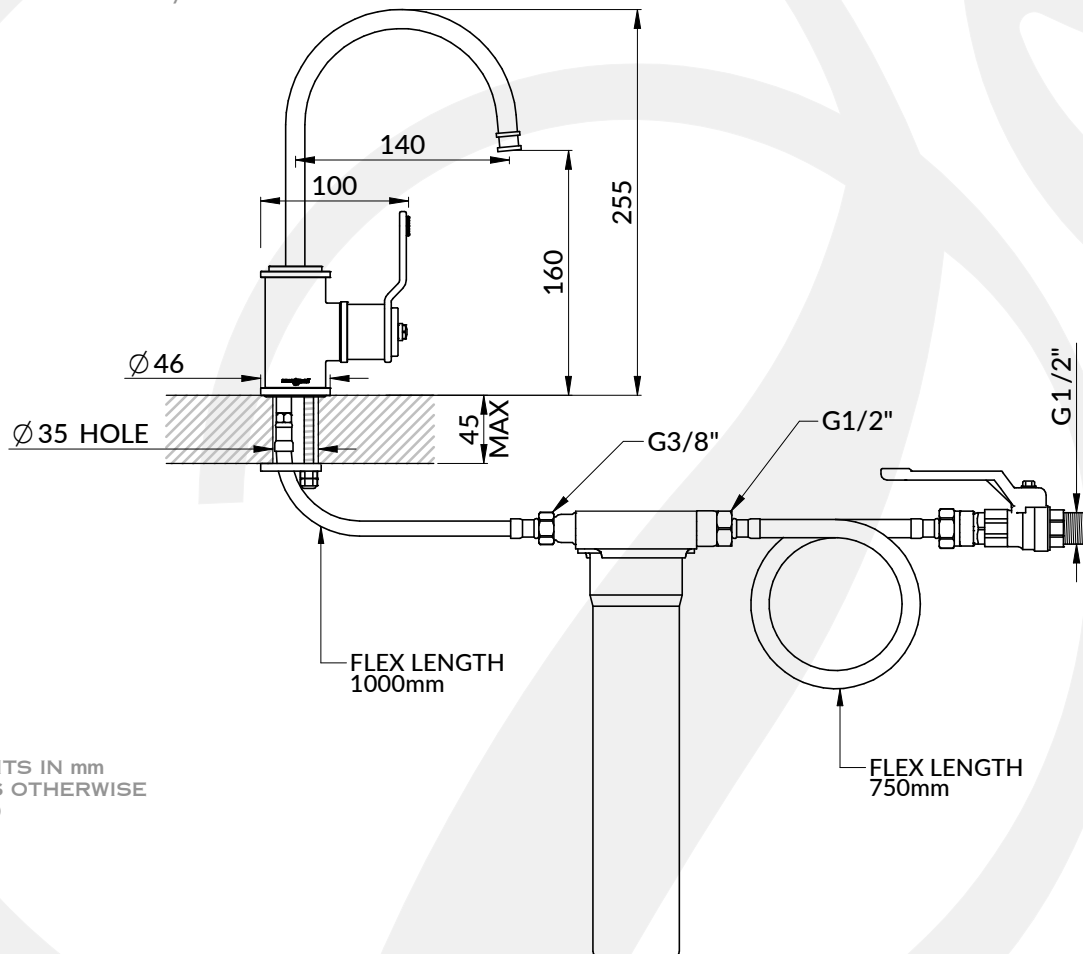

ALL UNITS IN mm
UNLESS OTHERWISE
STATED

Available Finishes:

- Chrome
- Nickel
- Pewter
- Polished Brass
- Satin Brass
- Aged Brass
- Gold
- English Bronze

• **Temp Range:**
Min 1°C / 34°F
Max 70°C / 158°F

• **Recommended Working Pressure:**
Min 1bar / 15psi
Max 5bar / 75psi

• **Packed Weight:**
3.1 kg

Available Options:

- Matching Armstrong Kitchen range